

PRESSURE OPERATED PUMPS POP

(1" x 1" to 3" x 2" – DN 25 x DN 25 to DN 80 x DN 50)

DESCRIPTION

The ADCAMat POP pressure operated pump is recommended in the transfer of steam condensate, oils and other non-hazardous liquids compatible with the construction, to a higher elevation or pressure. Under certain conditions, it can drain a closed vessel under vacuum or pressure. The pump can be operated using steam, compressed air or other gases, and is manufactured in carbon steel or stainless steel.

OPERATION

Liquid flows by gravity into the pump through an inlet check valve, lifting the float. At this point, the motive fluid intake valve is closed while the vent valve is open. As the float reaches its highest position the motive fluid intake valve opens and the vent valve closes, allowing the motive fluid to enter the pump body. The pressure in the pump builds up just enough to overcome backpressure.

The pressurized liquid opens the outlet check valve and the discharge starts. The liquid discharged may be quantified through a special counter, enabling the pump to function as a reliable flow meter.

When the float reaches its lower position the motive fluid intake valve closes and the vent valve opens allowing the liquid to fill the pump once again, repeating the cycle.

MAIN FEATURES

Hardened stainless steel wear parts.
High-endurance inconel springs.
Low filling head to minimize installation space.
No electric requirements or NPSH issues.
Suitable for hazardous environments.
Low running costs.

OPTIONS: Level gauge.
Stroke counters.

USE: To lift steam condensate and other liquids compatible with the construction.

AVAILABLE MODELS: POPS – carbon steel.
POPSS – stainless steel.

SIZES: 1" x 1", 1 1/2" x 1 1/2", 2" x 2" and 3" x 2";
DN 25 x DN 25, DN 40 x DN 40, DN 50 x DN 50
and DN 80 x DN 50.

CONNECTIONS: Flanged EN 1092-1 PN 16.
Flanged ASME B16.5 Class 150.
Female threaded ISO 7 Rp (threaded flanges).
Others on request.

INSTALLATION: Horizontal installation. An example is shown in Fig. 1.
See IMI – Installation and maintenance instructions.

MOTIVE MEDIUM: Saturated steam, compressed air, nitrogen and other gases.



CE MARKING – GROUP 2 (PED – EUROPEAN DIRECTIVE)	
PN 16	CATEGORY
All sizes	2 (CE marked)

BODY LIMITING CONDITIONS *				
POPS		POPSS		
FLANGED PN 16 / CLASS 150		FLANGED PN 16	FLANGED CL. 150	RELATED TEMP.
ALLOW. PRESS.	RELATED TEMP.	ALLOW. PRESS.	ALLOW. PRESS.	
16 bar	50 °C	16 bar	15,3 bar	50 °C
14 bar	100 °C	15 bar	13,3 bar	100 °C
13 bar	195 °C	12,7 bar	11,1 bar	200 °C
12 bar	250 °C	12 bar	10,2 bar	250 °C

* Rating according to EN 1092-1:2018.

LIMITING CONDITIONS	
Liquid specific gravity	0,8 to 1
Maximum viscosity	5° Engler
Maximum motive inlet pressure	10 bar
Minimum motive inlet pressure	0,5 bar
Maximum operating temperature	185 °C
Minimum operating temperature	0 °C
Pump discharge per cycle	16 L
Pump discharge per cycle (3" x 2" – DN 80 x 50)	25 L

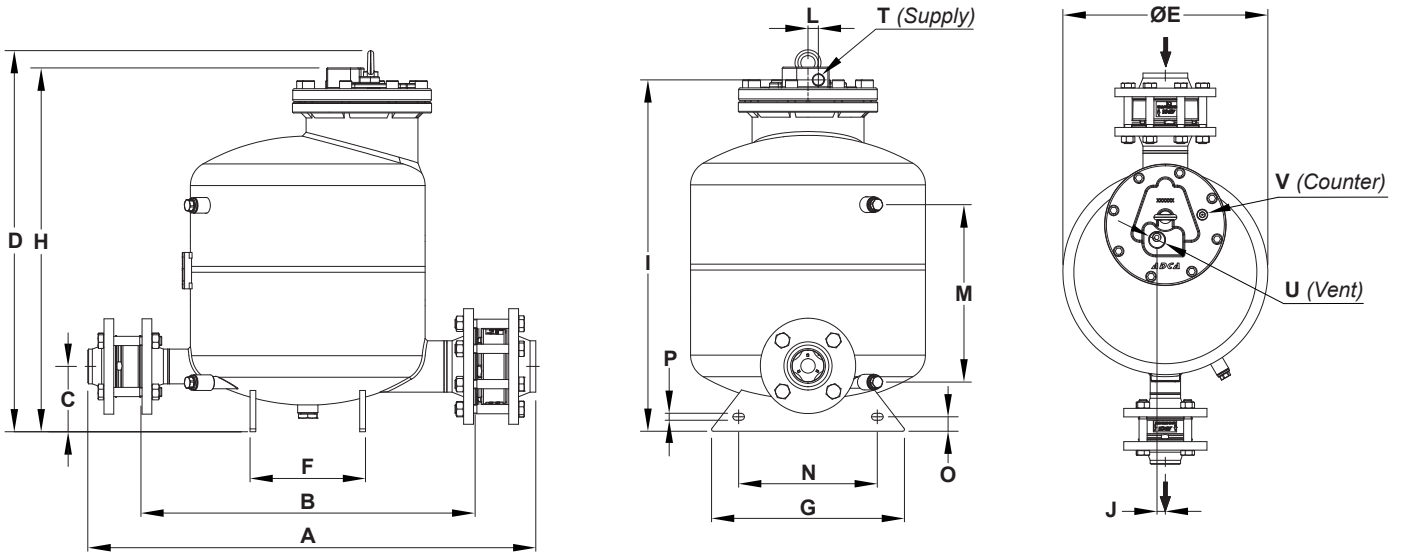

DIMENSIONS (mm)

SIZE	A *	B *	C	D	ØE	F	G	H	I	J	L	M	N	O	P	T **	U **	V **	WGT. (kg)	VOL. (L)
1" x 1" DN 25 x 25	578	444	100	640	323	160	244	617	598	17	18	327	150	25	12	1/2"	1"	1/2"	68	31,7
1 1/2" x 1 1/2" DN 40 x 40	615	454	100	640	323	160	244	617	598	17	18	327	150	25	12	1/2"	1"	1/2"	72,7	31,8
2" x 2" DN 50 x 50	644	460	100	640	323	160	244	617	598	17	18	327	150	25	12	1/2"	1"	1/2"	76,5	31,9
3" x 2" DN 80 x 50	776	580	113	650	406	200	334	627	608	17	18	307	240	25	12	1/2"	1"	1/2"	95,8	48,9

* With EN 1092-1 welding neck flanges. Dimensions may differ if ASME B16.5 flanges or ISO 7 Rp female threaded flanges are requested. Consult the manufacturer.

** As standard, in versions manufactured with EN 1092-1 PN 16 flanges, these connections are female threaded ISO 7 Rp. In versions with ASME B16.5 flanges, these connections are female threaded NPT.

MATERIALS

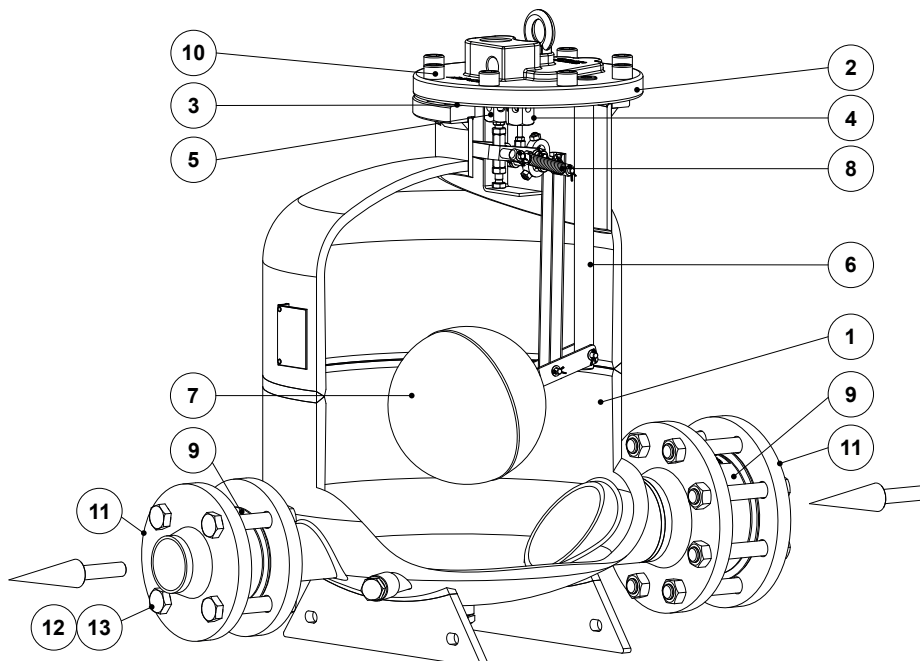

MATERIALS			
POS. No.	DESIGNATION	POPS	POPSS
1	Pump body	P265GH / 1.0425; P235GH / 1.0345; S235JR / 1.0038; P250GH / 1.0460	AISI 316 / 1.4401; AISI 304 / 1.4301
2	Cover	WCB / 1.0619	A351 CF8M / 1.4408
3	* Cover gasket	Stainless steel / Graphite	Stainless steel / Graphite
4	* Intake valve/seat assembly	Stainless steel	Stainless steel
5	* Exhaust valve/seat assembly	Stainless steel	Stainless steel
6	Lever assembly	Stainless steel	Stainless steel
7	* Float	Stainless steel	Stainless steel
8	* Spring assembly	Inconel	Inconel
9	* Check valve	A351 CF8M / 1.4408	A351 CF8M / 1.4408
10	Bolt	Steel 8.8	Stainless steel A2-70
11	Counter flange	P250GH / 1.0460	AISI 316 / 1.4401
12	Bolt	Zinc plated steel	Stainless steel A2-70
13	Nut	Zinc plated steel	Stainless steel A2-70

* Available spare parts.

SIZING

To accurately size a pressure operated pump, the following information must be provided:

1. The condensate load (kg/h).
2. The operating medium (steam, compressed air or other gases) and its pressure.
3. The total lift or backpressure in bar the pump will have to overcome. This includes the change in fluid level elevation after the pump (0,0981 bar/m of lift), plus pressure in the return piping, plus the pressure drop caused by pipe friction and other system components.
4. Available filling head in mm or any other dimension that allows its determination.

Table 1

CAPACITY CORRECTION FACTOR FOR GASES OTHER THAN STEAM					
% BACKPRESSURE VS MOTIVE PRESSURE (BP/MP)	10%	30%	50%	70%	90%
Correction factor	1,04	1,08	1,12	1,18	1,28

Table 2

CAPACITY CORRECTION FACTORS FOR FILLING HEADS OTHER THAN 300 mm				
PUMP SIZE	FILLING HEAD (mm)			
	150	300	600	900
1" x 1" – DN 25 x 25	0,7	1	1,2	1,35
1 1/2" x 1 1/2" – DN 40 x 40	0,7	1	1,2	1,35
2" x 2" DN 50 x 50	0,7	1	1,2	1,35
3" x 2" – DN 80 x 50	0,9	1	1,08	1,2

RECEIVER

A receiver is recommended to temporarily hold the liquid and prevent any flooding of the equipment, while the pump is performing a pumping cycle. A definable length of large diameter pipe can be used. Suggested receiver sizes are shown in Table 3.

Table 3

RECEIVER				
PUMP SIZE	1" x 1" – DN 25 x 25	1 1/2" x 1 1/2" – DN 40 x 40	2" x 2" – DN 50 x 50	3" x 2" – DN 80 x 50
Pipe size with 1 m length	6"	6"	8"	10"

Table 4

FLOW RATE (kg/h) INSTALLATION WITH 300 mm FILLING HEAD ABOVE THE PUMP COVER						
MOTIVE PRESS. (bar)	TOTAL LIFT (bar)	1" x 1" – DN 25 x 25	1 1/2" x 1 1/2" – DN 40 x 40	2" x 2" – DN 50 x 50	3" x 2" – DN 80 x 50	
1	0,35	840	1490	2320	4480	
2		1030	1520	3160	5240	
3		1140	1640	3560	5640	
4		1180	1680	3840	5840	
5		1240	1740	3910	5900	
6		1270	1760	3940	5980	
8		1300	2200	3990	6030	
10		1310	2205	4000	6080	
2		1	805	1560	2550	4080
3			940	1790	2990	4720
4	1080		1930	3160	5080	
5	1110		2010	3200	5280	
6	1140		2090	3250	5400	
8	1180		2190	3280	5490	
10	1190		2200	3320	5560	
3	2		780	1495	2470	3510
4			900	1690	2620	3950
5			1000	1820	2830	4230
6		1040	1910	2860	4740	
8		1100	2010	2880	4880	
10		1110	2060	2900	4960	
4		3	740	1400	2360	3480
5			860	1545	2540	3640
6			910	1675	2560	3720
8			970	1805	2590	4050
10	980		1850	2650	4110	
5	4	720	1335	2280	2690	
6		820	1480	2460	2860	
8		910	1675	2500	3190	
10		930	1760	2540	3380	
6	5	680	1290	2080	2520	
8		740	1530	2180	2740	
10		810	1630	2220	2860	
7	6	660	1230	1880	1940	
8		730	1370	1940	2240	
10		820	1490	2150	2360	

Remark: Based on liquid specific gravity of 0,9 to 1,0.

Example

Condensate load	1800 kg/h
Filling head	150 mm
Motive fluid	Compressed air
Available pressure	8 bar
Vertical lift after pump	6 m
Return piping pressure	1,5 bar
Piping friction pressure drop	Negligible

Calculations:

Total backpressure: 1,5 bar + (6 m x 0,0981) = 2,09 bar.

Assuming steam as motive medium at a pressure of 8 bar and a total backpressure of 3 bar, then according to Table 4 a DN 50 x 50 pump, with a capacity of 2590 kg/h, is the recommended size.

Filling head correction:

With 150 mm filling head the correction factor from Table 2 is 0,7. The corrected capacity is thus 2590 kg/h x 0,7 = 1813 kg/h.

Correction for air as a motive medium:

The % backpressure is 2,09 bar / 8 bar = 30%. The correction factor from Table 1 is 1,08.

The corrected capacity is thus 1813 kg/h x 1,08 = 1958 kg/h, and so, a DN 50 x 50 pump is still the recommended size.

TYPICAL APPLICATIONS

CONDENSATE RECOVERY IN AN OPEN LOOP SYSTEM

The pump transfers high temperature condensate without cavitation problems. The vent line must be unrestricted and self draining to the receiver (Fig. 1).

REMOVAL OF CONDENSATE UNDER PRESSURE WITH PUMP AND STEAM TRAP COMBINATION

The pump is installed in a closed loop with its vent connected to a pressurized receiver (Fig. 2).

When steam pressure is sufficient to overcome backpressure, the steam trap operates. As soon as, e.g., the equipment's control valve starts to modulate, the steam pressure will decrease (even vacuum can occur). The lower differential pressure decreases the steam trap ability to discharge, causing the condensate level to rise inside the body of the pump. Once the pump float reaches its higher position, the intake valve opens and steam replaces the necessary positive pressure to pump out the condensate.

DRAINAGE OF A SINGLE UNIT UNDER VACUUM

This configuration works with units operating with a minimum absolute pressure of 0,2 bar (Fig. 3).

For proper operation the filling head (H1) must range between 1 and 2 meters. The lift (H) must be as minimum as possible, but never less than 1 meter, otherwise a siphon with height (H2) is required.

Steam must be used as motive medium, and its maximum pressure should not exceed 3 bar.

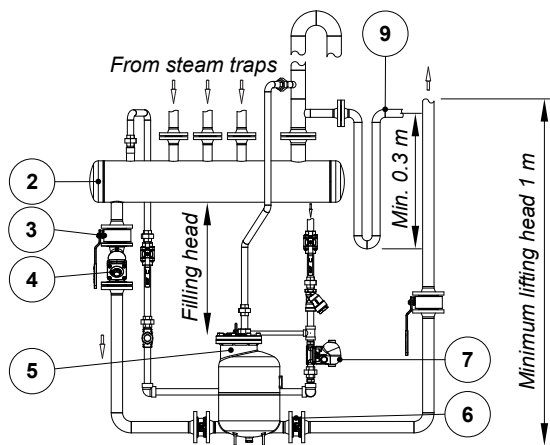

Fig. 1

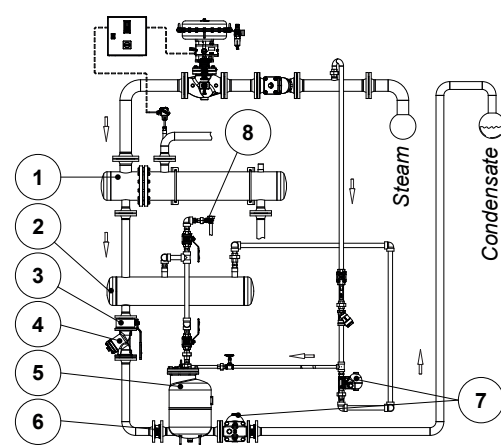

Fig. 2

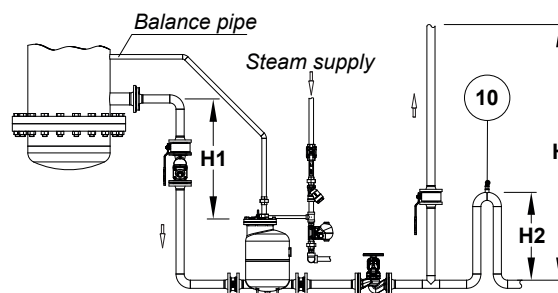

Fig. 3

EQUIPMENT			
POS. No.	DESIGNATION	POS. No.	DESIGNATION
1	Heat exchanger	6	Check valve
2	Receiver	7	Steam trap
3	Shut-off valve	8	Air vent
4	Y strainer	9	Overflow
5	Pump	10	Vacuum breaker